



Clark Standard Bunded Grab Tanks are available in three tank sizes - 850 litre, 1150 litre and 1500 litre. The tanks are constructed from heavy gauge pressed steel with 6mm steel end plates. The inner tank is manufactured from thick section polyethylene which offers improved cleanliness over steel lined tanks. A lockable steel lid with protected padlock hasp is fitted to the outer steel tank, the inner tank employs a 6" screw on lid with 'O' ring seal. Clark Grab Tanks are available with a range of additional options.



## The Clark Dual Grab Bar System

Clark Grab Tanks and Grab Boxes employ the new dual grab bar, incorporating plastic sleeved ends, for lifting via the harvester head and a bare steel centre section for lifting via timber grapples.

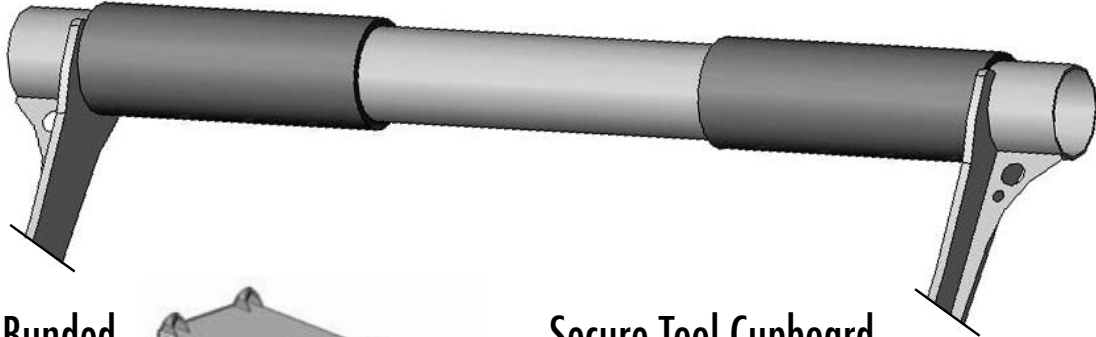

## Clark Standard Bunded Grab Tank Options

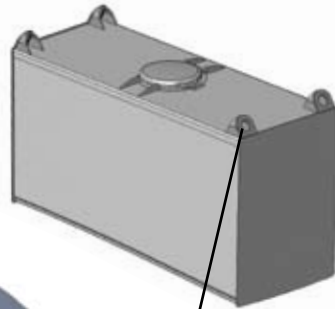

Option:  
Available With  
Lifting Eyes



## Secure Tool Cupboard

A tool cupboard can be specified at the time of ordering. Fitted with one shelf plate, the cupboard has space for two 25 litre oil drums plus other items of equipment. The tool cupboard door is secured by a protected padlock hasp.



Tank Model	Part No	Capacity Litres	Weight Empty Kg	Full Weight Diesel Kg	Full Weight Urea Kg	Width mm	Length mm	Height to Top of Bar mm
Standard Bunded Tank 850 litre	BGT850	850	365	1080	1215	740	1560	1720
Standard Bunded Tank 1150 litre	BGT1150	1150	405	1370	1555	740	2060	1720
Standard Bunded Tank 1500 litre	BGT1500	1500	460	1720	1960	740	2060	2020

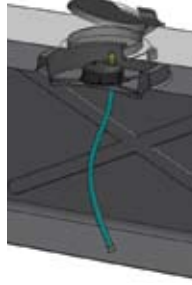

## Refuelling Hose & Dip Tube

A 4 metre refuelling hose and dip tube fitted with quick release couplings is available for use on all our standard tanks. The dip tube remains permanently connected to the tank through the tank inner cap with an outer quick release connection. The hose can be stored coiled up inside the steel tank and offers fast spill free machine refuelling.



## Hand or Electric Refuelling Pump

A hand pump or 12v/24v electric pump can be specified for our range of standard tanks. Fitted inside the tank tool cupboard, pumps are supplied complete with suction and delivery hoses, creating a stand alone refuelling station... wherever the location.



## Paint Colour Options

The standard paint colour of Clark Grab Tanks is black, however other colours may be specified at the time of ordering, including the camouflage paint option shown here.

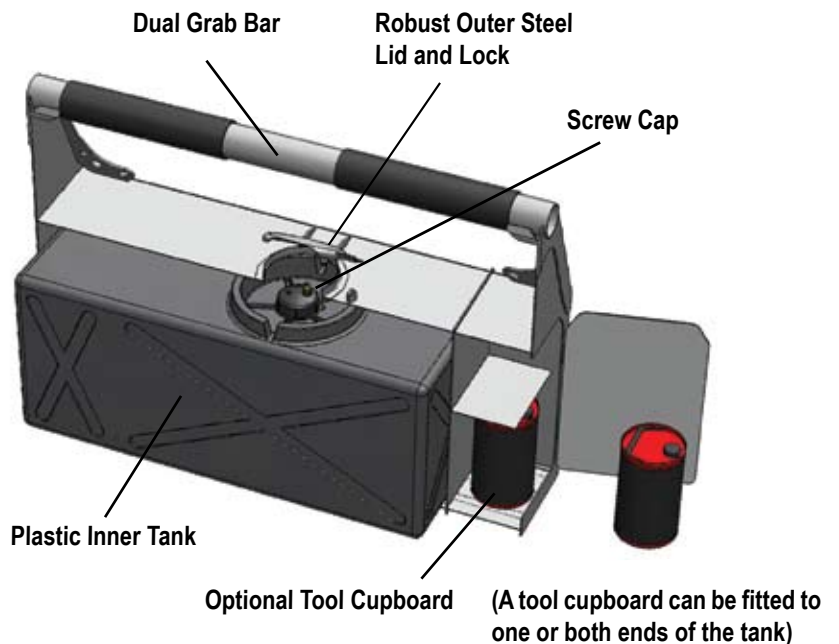

Tanks are for static site use only and not designed for the movement of fuel on the public highway



Please Specify Options At Time Of Ordering

Tank Model	Option Tool Cupboard	Option Refuelling Hose	Option Hand Pump	Option Electric Pump
Standard Bunded Tank 850 litre	BGT-TC	BGT-RH	Yes - Contact Sales	Yes - Contact Sales
Standard Bunded Tank 1150 litre	BGT-TC	BGT-RH	Yes - Contact Sales	Yes - Contact Sales
Standard Bunded Tank 1500 litre	BGT-TC	BGT-RH	Yes - Contact Sales	Yes - Contact Sales