



**Twin Drum**

Shown With Optional  
Gear Pump System For  
Pumping Chain Oil

**For Safe, Secure Storage Of Oil In The Forest**

Drum Store - an innovative addition to the Clark Grab Box family. Drum Store models are available to hold either one or two standard 205 litre (45 gallon) oil drums plus a secure store cupboard - a useful addition to all harvesting sites. Oil drums can be loaded into the drum bunds by simply swinging the grab bar back and using the drum lifting chains to quickly and safely load and unload drums.



REGISTERED DESIGN



Pump System  
Connected To Drum



Screw In Dip Tube & Breather Valve Fitted

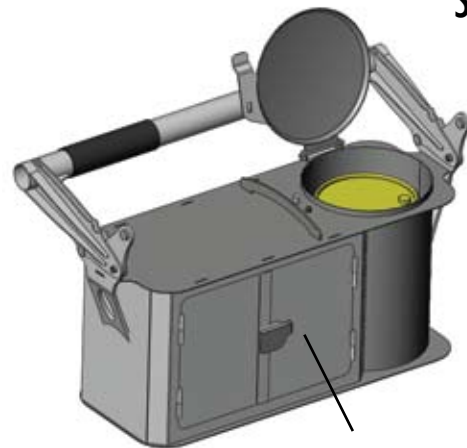

Single Drum

Extra Large Capacity Storage Cupboard

The single drum model of the Clark Grab Box Drum store is similar in dimensions to the twin drum model but features an extra-large capacity storage cupboard.



Standard Design Features

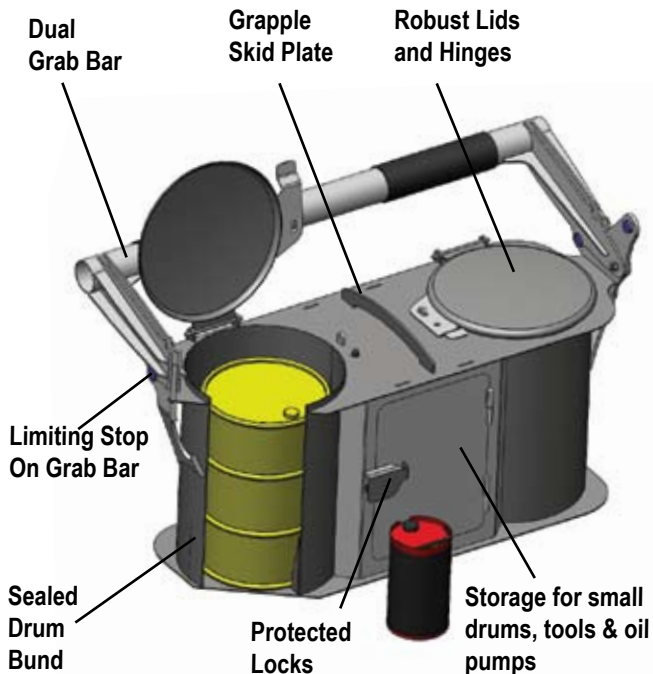

Options



Drum Lifting Chains

Specially designed for handling 205 litre [45 gallon] oil drums, these chains offer a unique solution to safe lifting and handling with the ability to clamp to drums for vertical or horizontal lifting. Light, compact and easy to store. Safe working load on both chains 500kg.

Lifting Chains DLC-500

Drum Dip Tube

Screw on dip tube & breather valve for use with pump systems.

Hand Or Electric Pumps

A hand pump or 12v/24v electric pump can be supplied with our drum stores, complete with suction and delivery hoses, for the safe, easy transfer of forest machine hydraulic oil and the filling of chain oil tanks.



Gear Pump



For pumping heavy oils



Hydraulic Oil Transfer Pump



For pumping hydraulic oils

Please Specify Options At Time Of Ordering

Drum Store Model	Length mm	Width mm	Height To Top Of Tank mm	Weight Empty Kg
DS2-205 Twin Drum Store	2320	840	1080	550
DS1-205 Single Drum Store	2320	840	1080	565