

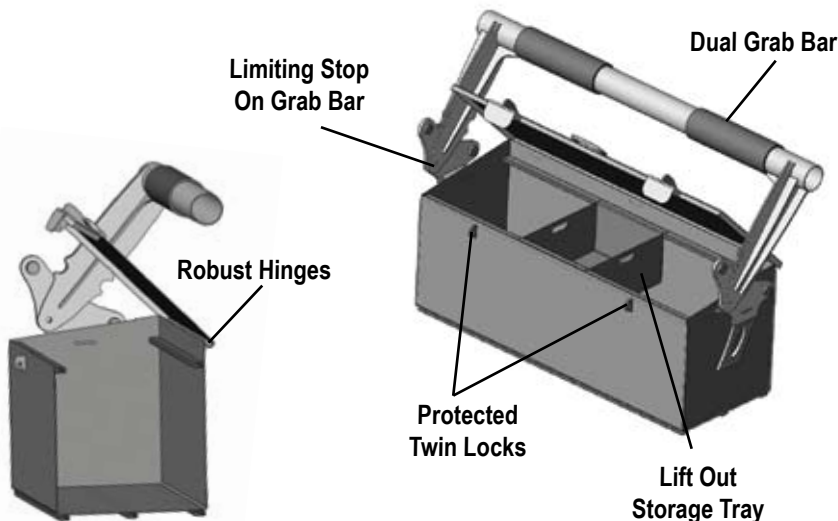

For Secure Equipment Storage In The Forest

Tool Store - a new addition to the Clark Grab Box range, offers a compact solution for the secure storage of tools and equipment. The lockable lid opens fully to offer unrestricted access by means of our patented Grab Bar Pivot System - allowing easy lifting by both harvester heads and grapples.



Drum Store Model	Length mm	Width mm	Box Height mm	Weight Empty Kg
TS1500	1500	870	875	280
TS2000	2000	870	875	360

Options

Box Divider Plates
Wooden Floor
Paint Colour

