

# ExTe

Securing cargo. We invented the Concept.

Exte are Europe's largest manufacturer of bunks, having specialised exclusively in this field for over 50 years, they have concentrated on developing superior products for a wide range of applications. ExTe produce bunks of minimal weight, maximum strength and enviable safety - not only to vehicle operators, but to other road users as well.



## Exte Stakes

Exte stakes are available in one piece or two piece telescopic. The unique cam locking adjustment of telescopic stakes ensures secure height adjustment with a fast action. Load heights up to 3.2m are available. Exte stakes are available with standard bolt locking or a quick lock fixing for fast removal.

**Exte A Series**

A Unique Innovation:  
25% Lighter



**Bunks That Load More Timber**

A-series is Exte's third generation of aluminium bunks and the lightest on the market. A-series is designed to meet the demand for extremely lightweight bunks, which make it possible to load more timber and increase profitability for the haulier. A-series was introduced in 2005 and has been a total success.

**Smart Use Of Material**

The profiles of the bunks have been optimised so that more material is placed where the load is greatest. This increases safety and decreases weight.

**Quick Fit**

The pre-drilled frame and specially developed attachments allow the bunks to be fitted very quickly. This saves time and reduces costs. No welding is required. Consequently, the bunks can be easily moved between different frame widths.

**Stabilising Flange**

The frame flanges ensure the stability of the bunks.

**Rational Stakes**

The E and A series both have the same stakes, which means that the storage of stakes is rationalised for equipment installers and for hauliers with several units.

The A Series is designed to handle loads of 4 tonnes (A4), 6 tonnes (A6) or 9 tonnes (A9) Available with telescopic or one piece stakes.

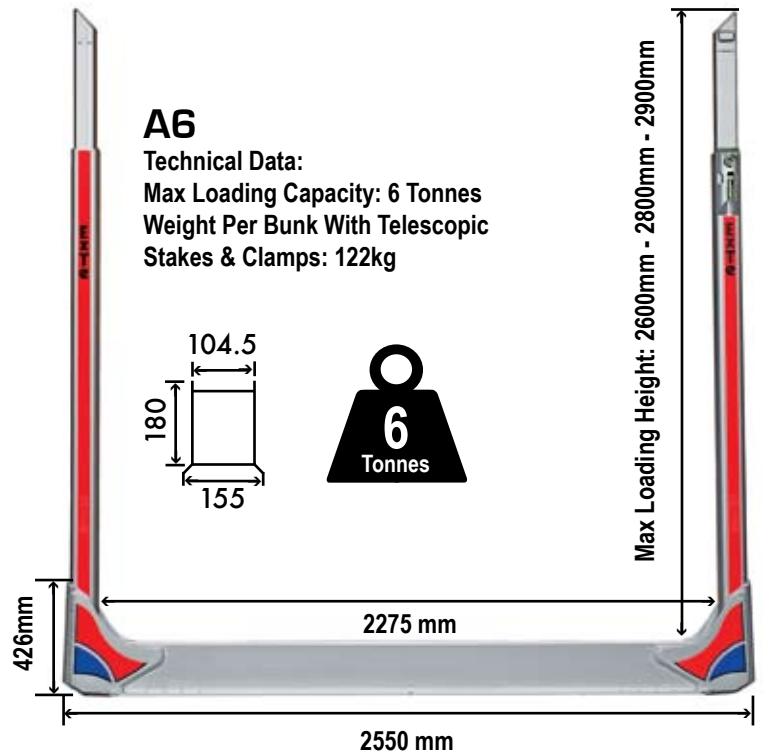
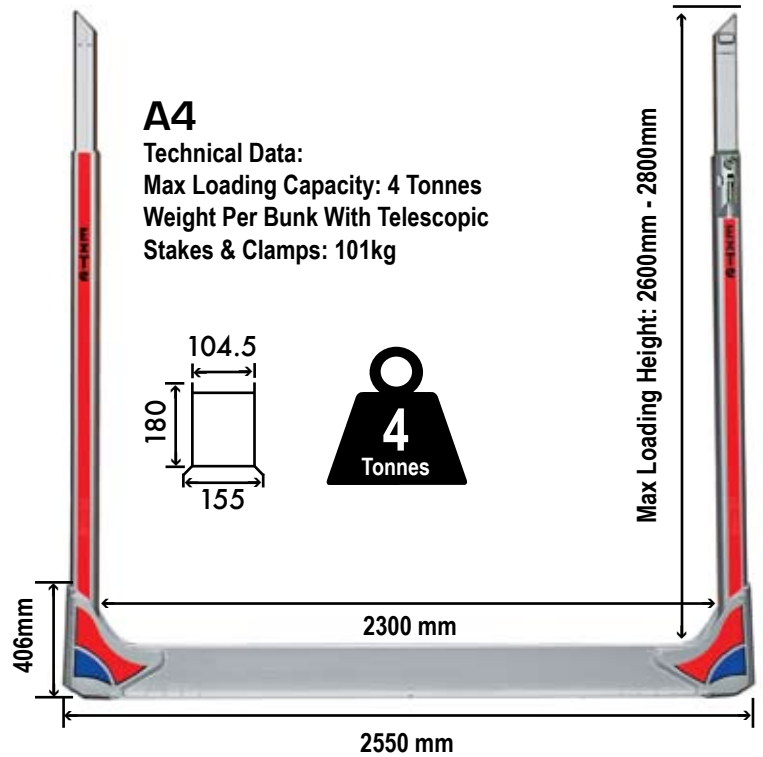

A Series  
Alloy Wedge



**Exte Type 144 Timber Transport System** Provides Maximum Flexibility

System 144 combines a steel cross member with steel and alloy stakes making it ideally suited to transporting round hardwood timber and other high stress loads. The heavy duty design and construction provides superior resistance to shock loads during loading and unloading.



The maximum permissible load per bunk is 7 tonnes, with each bunk, including stakes, weighing around 160kg.

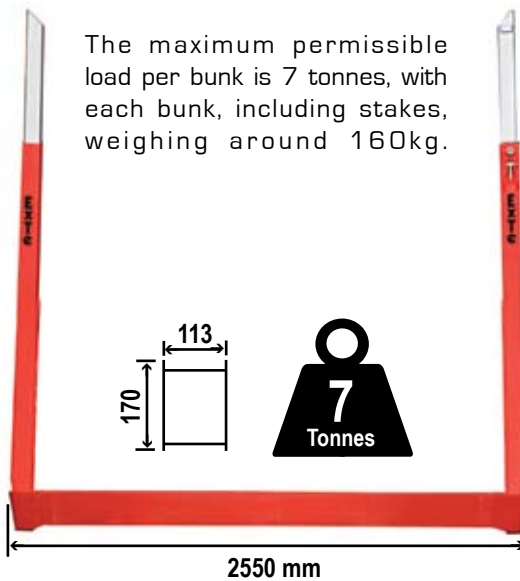

Type 144 Quicklock Telescopic Stake

Type 144 Telescopic Stake

Type 144 One Piece Euro Stake

**ExTe**

**Type 144 Quicklock**

Type 144 Quicklock stakes are available to fit standard sockets. Designed for use on flatbed trucks, Quicklock stakes employ a secure springloaded camlock design for fast installation and removal.

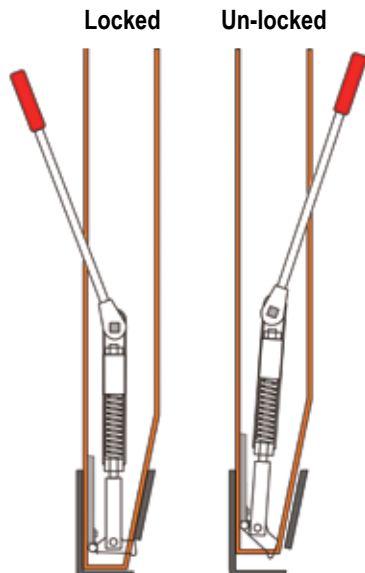

Unique ExTe Telescopic Stake Locking Mechanism



**Type 144 Socket**

144 Weld on socket for truck chassis mounting

**Exte E Series** The Lightest Combination Bunks On The Market

E Series One Piece Euro Stake



**E-Bunks For All Applications**

The combination of steel frames and aluminium stakes make the E-series combination bunks the most popular on the market.

All the bunks are lightweight relative to their loading capacities.

E-bunks give hauliers unlimited opportunity to select just the right bunk for the job, from the easily handled 4 tonne bunks to the robust and extremely heavy-duty 12 tonne variants. Low weight means easier handling, greater loading capacity and improved profitability.

Available with telescopic or one-piece stakes.

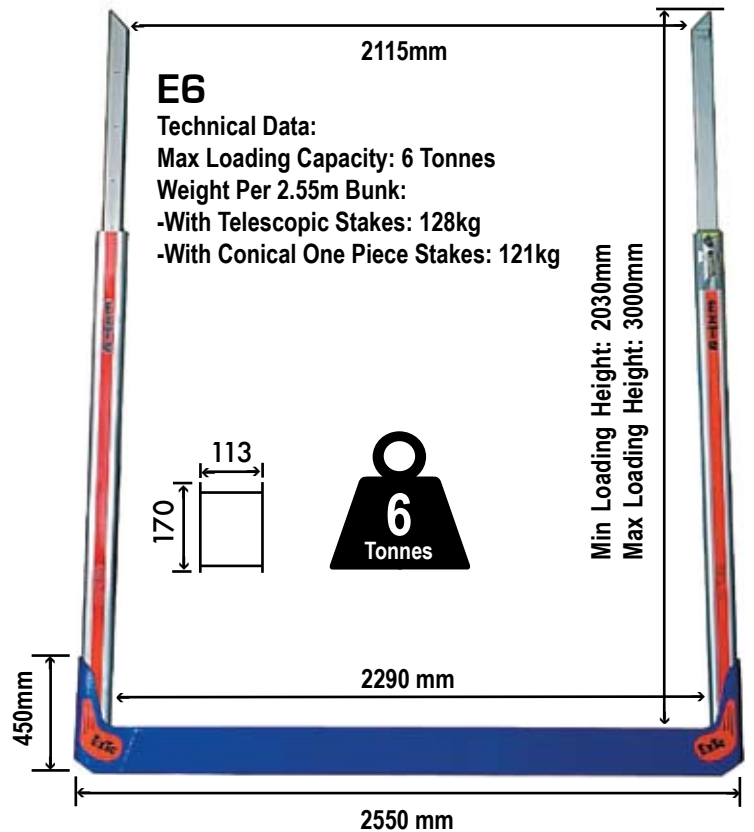
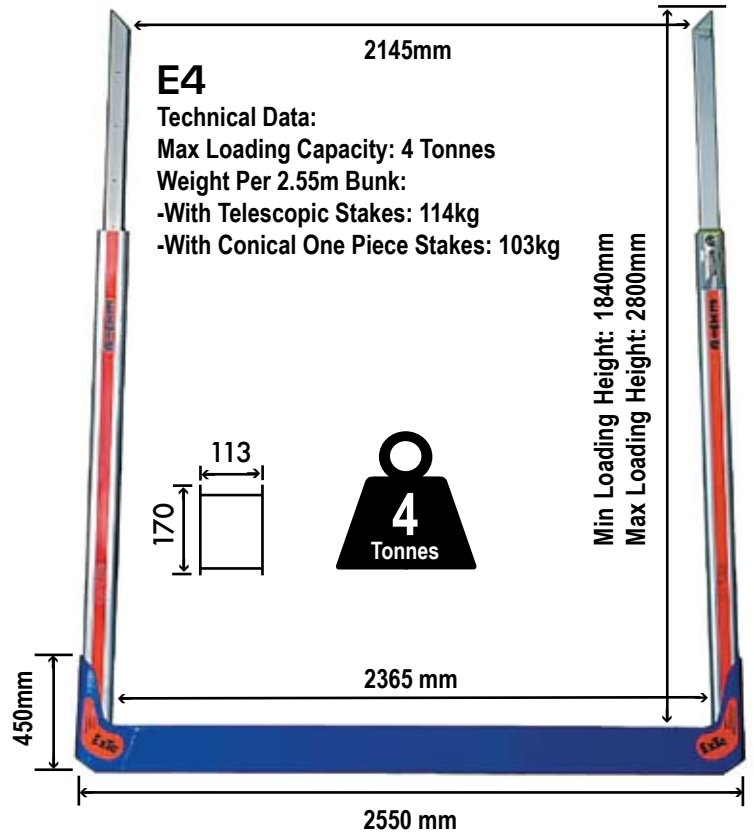

**Exte E Series**

The Lightest Combination Bunks On The Market

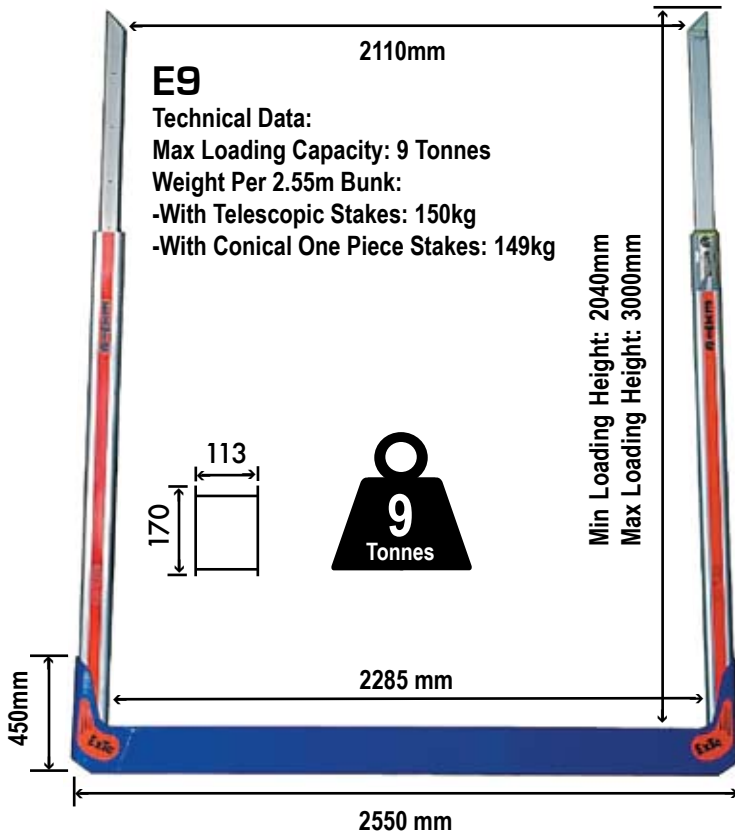

**E Series Alloy Wedge**



**E Series Weld On Sockets**

Weld-On sockets are available for platform bodied vehicles, where stakes are to be fitted. The sockets are manufactured from steel and in the same quality as the sockets in the bolster frames. The material is heat treated and well suited for welding without the need for preheating.



For Full Clamp Details - See Page 6



**Clamping Attachments for Bolsters of Steel**

A range of clamping attachments are available for use with bunks including standard bolted types, nylon pad sliding types and cam lock roller sliding clamps for fast movement of bunks.

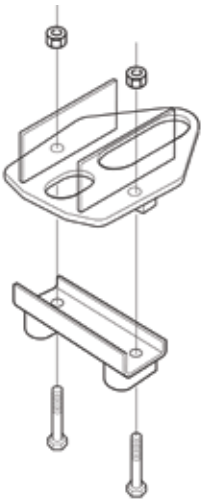

**Weld On  
Clamp**  
800670

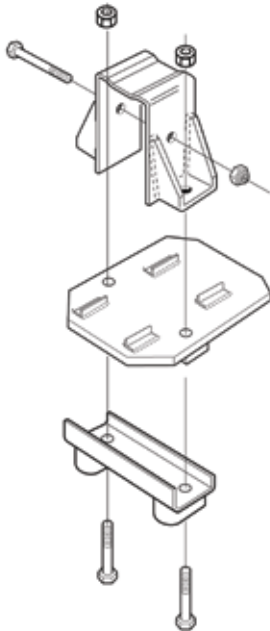

**Bolt On  
Clamp**  
800760

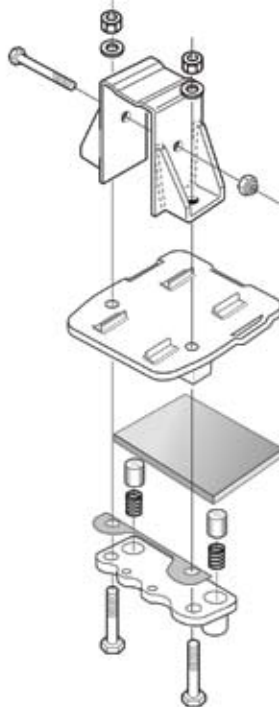

**Bolt On  
Nylon Slide Clamp**  
800780

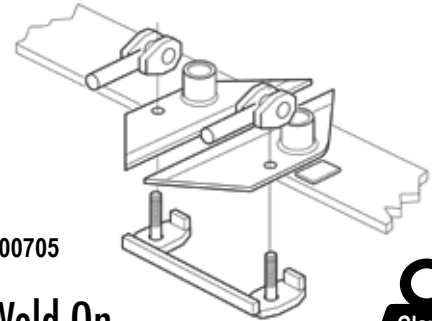

800705  
**Weld On  
Cam Lock Roller Clamp**

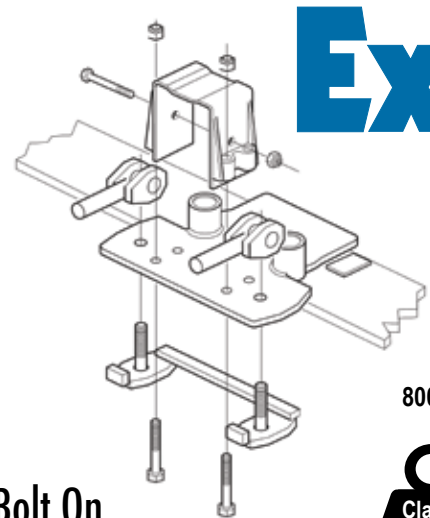

**Bolt On  
Cam Lock Roller Clamp**



**Autonordic Load Winches**

We offer two models of load winches from Autonordic for attachment to truck chassis. These winches offer a secure solution to load restraint and are especially suited to timber transport applications - both can be operated by a ratchet and socket or tommy bar and incorporate a fast wind up handle.



**Type 601 Winch**



Holds 10m  
of Strap

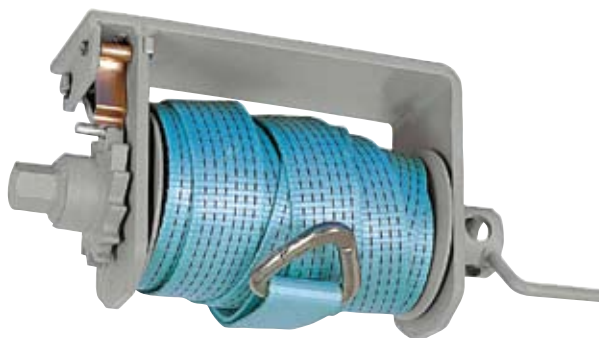

**Type 602 Winch**



Holds 10m  
of Strap



**Weld On  
Strap Hook**

