

IR Series Rotators

Designed for the toughest of applications and working environments, IR Rotators are available in a range of sizes and models. IR Rotators incorporate a twin taper roller bearing design in robust housings and are available with static load ratings up to 45 tonnes. IR Rotators are designed to be mounted inside the headstock of attachments and can be supplied with mounting adaptors, upper suspension links and hose guards to suit each specific application.



IR10



Designed for use in the toughest of industrial applications, the IR10 is of robust construction and is suitable for large cranes and excavators.

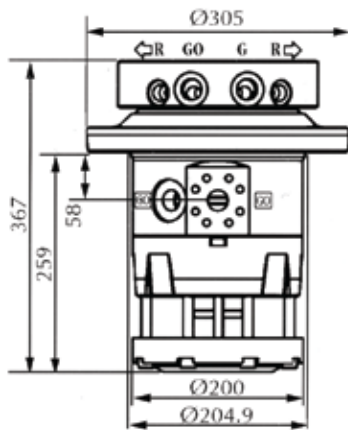

CRANE LINKS
IR
Page 3



Technical Data	IR10 M16	IR10 M20
Upper Bolt Hole Diameter	16mm	20mm
Rotation	Continuous	Continuous
Weight	84kg	87kg
Max Axial Load Static	±250kN	±250kN
Max Axial Load Dynamic	±70kN	±70kN
Torque at 20MPa (2900psi)	2200Nm	2200Nm
Recommended Oilflow	25 l/min	25 l/min

IR20



The ultimate industrial rotator, IR20 is designed for extremely demanding working environments. Built to the same overall design and exacting standards as the IR10, the IR20 incorporates heavy duty bearings capable of taking static loads up to 45 tonnes.

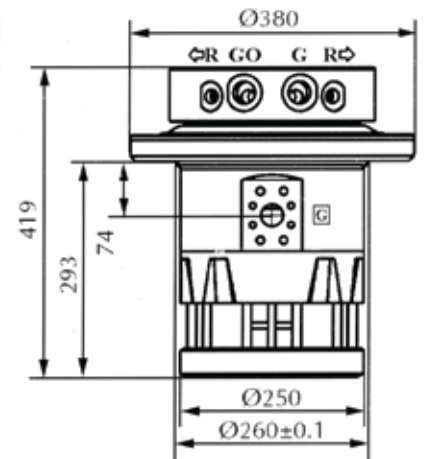

CRANE LINKS
IR
Page 3



Technical Data	IR20 M20	IR20 M24
Upper Bolt Hole Diameter	20mm	24mm
Rotation	Continuous	Continuous
Weight	145kg	150kg
Max Axial Load Static	±450kN	±450kN
Max Axial Load Dynamic	±120kN	±120kN
Torque at 20MPa (2900psi)	3300Nm	3300Nm
Recommended Oilflow	35 l/min	35 l/min

IR - HX rotators with additional oil channels are available to order

IR12



IR12AV



IR22



Similar in construction to the IR10, the IR12 rotator has dual oil feed ports to each side making it ideal for use with heavy duty timber grapples. The IR12 employs a high torque slew motor suitable for use in the most demanding applications.

Designed specially for use on timber harvesters, the IR12AV employs the AV system of slew motor oil being fed from the harvester head to the lower body of the rotator. Employing a high torque slew motor and robust upper link, the IR12 is suitable for use with the largest harvester heads.

Like the IR12, the IR22 rotator has dual oil feed ports to each side for heavy duty grapple use which combined with the extra torque slew motor and robust upper linkage mount makes the IR22 suitable for use on the largest of grapples and attachments.

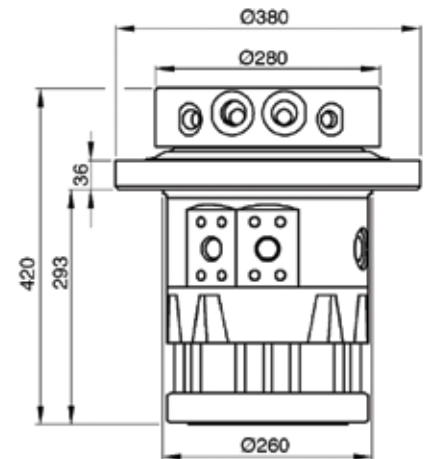
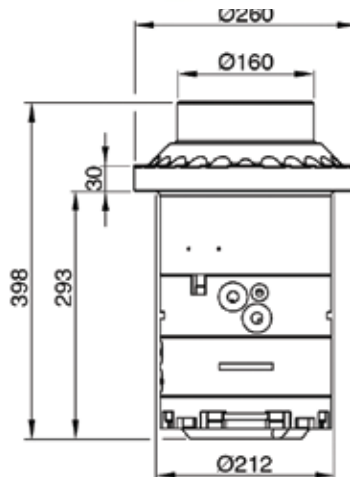
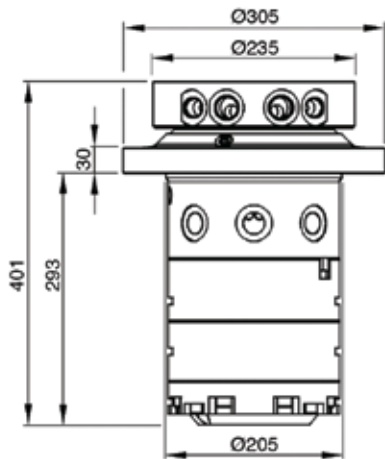

CRANE LINKS
IR
Page 3



CRANE LINKS
IR
Page 3



Technical Data	IR12	IR12AV
Rotation	Continuous	Continuous
Weight	97kg	82kg
Max Axial Load Static	±250kN	±300kN
Max Axial Load Dynamic	±70kN	±100kN
Torque at 20MPa (2900psi)	2900Nm	2900Nm
Recommended Oilflow	25 l/min	25 l/min

Technical Data	IR22
Rotation	Continuous
Weight	150kg
Max Axial Load Static	±450kN
Max Axial Load Dynamic	±150kN
Torque at 25MPa (2900psi)	4100Nm
Recommended Oilflow	35 l/min

IR Series Crane Links & Rotator Link Plates



IR 10/12
Link Plate
c/w Pin



IR 20/22
Link Plate
c/w Pin



IR 10/12
Hose Guard



IR 20/22
Hose Guard



IR 10/12
Excavator
Link



IR 20/22
Excavator
Link



IR 10/12 Links



Bossed
Link Plates



Weld On
Link
IR 10/12

